

**COMPLIES WITH:**

Anne Arundel Co. D-25  
 Baltimore Co. D-2.02  
 Howard Co. SD 4.02

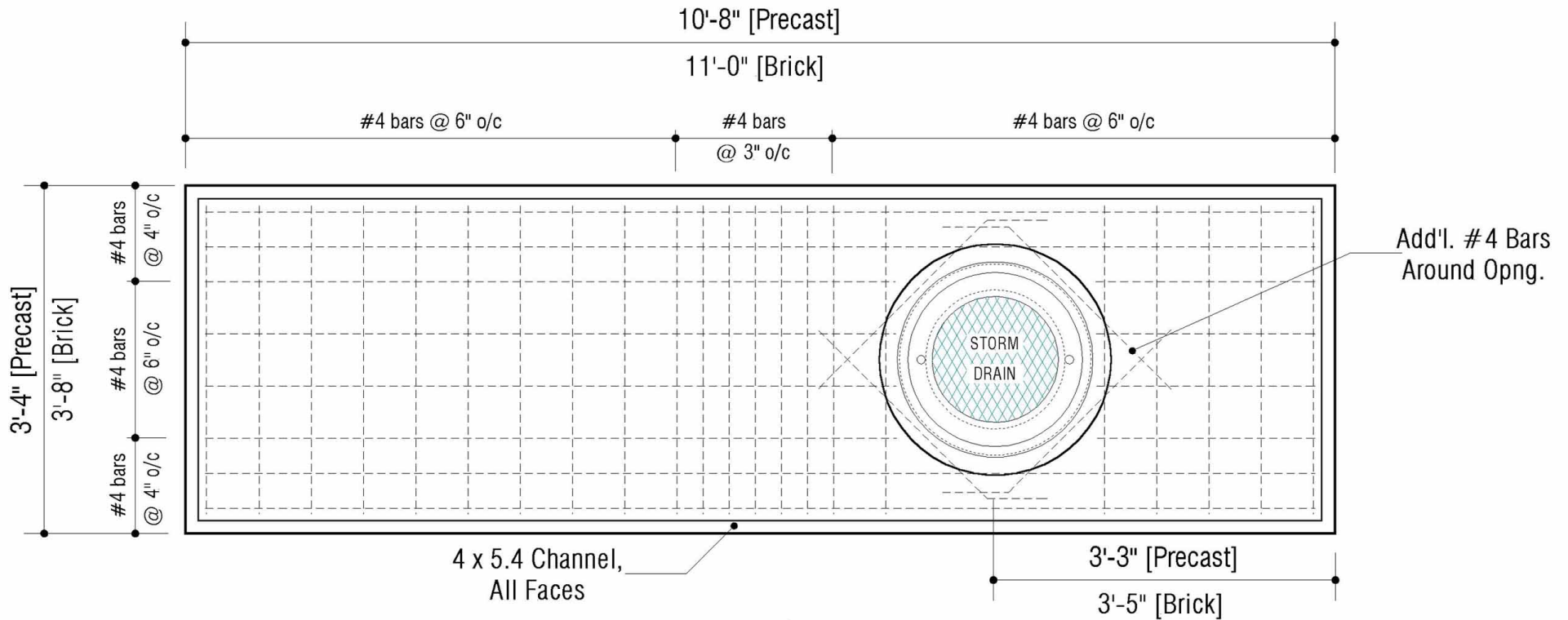

**TOP SLAB PLAN**



6264 Race Road  
 Elkridge, Maryland 21075  
 Tel. 410.796.1434  
 Fax. 410.796.1438

www.mayerbrosprecast.com

**A-10/B-1 INLET TOP SLAB**  
**[For Precast or Brick Inlet]**  
 Stock Item

Dwg.# A10-B1

No Scale

Jan. 1, 2000

**DESIGN DATA & GENERAL NOTES**

- [1] Concrete strength  $f'_c=4,500$  p.s.i. @ 28 days. Density = 150 pcf.
- [2] Cement - Portland Type I/II per ASTM C 150-92.
- [3] Admixtures per ASTM C 260-86 & C 494-92.
- [4] Reinforcing per ASTM A615, Grade 60, domestic. Min 1-1/2" cover.
- [5] Light broom finish w/ radiused exposed edges.
- [6] Primed channel to receive one [1] shop coat of approved paint.
- [7] Slab thickness, 4" typ.